

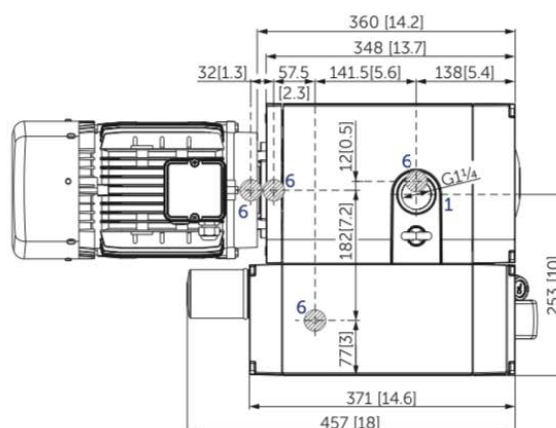

Model: **U 5.101**

SPECIFICATIONS

Volume flow 50 Hz	100 m ³ /h
Vacuum absolute 50 Hz	≤0.1 mbar
Power 50 Hz	2.2 kW
Noise Level 50 Hz	65 dB(A)
Volume flow 60 Hz	120 m ³ /h
Vacuum absolute 60 Hz	≤0.1 mbar
Power 60 Hz	2.2...2.64 kW
Noise Level 60 Hz	68 dB(A)
Weight	40 kg without motor

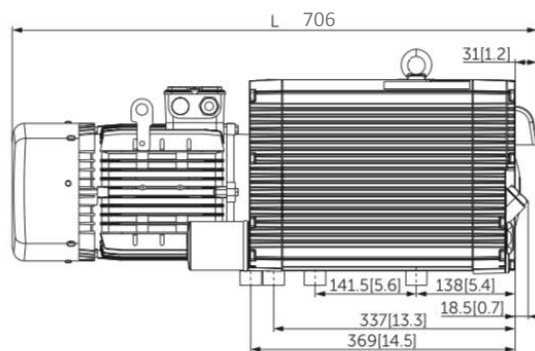
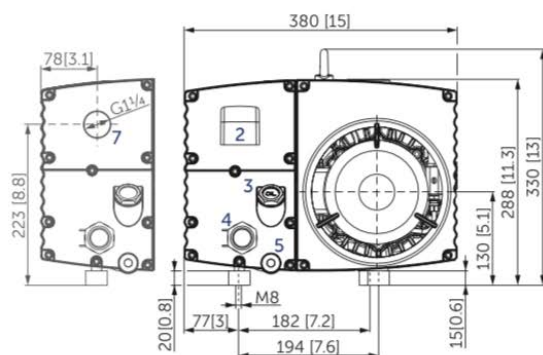

- 1 Vacuum connection (G1¼)
 - 2 Exhaust air (diverter)
 - 3 Oil filler cap (G¾)
 - 4 Oil sight glas (G1)
 - 5 Screw plug for oil drain (G½)
 - 6 Rubber buffer position
 - 7 optional: threaded connector for exhaust air (G1¼)
- incl. gas ballast valve, non-return valve, oil separator and oil filter
 - The motor illustration may vary
 - Dimensions in mm [inch]